



# SISTEMI PER CANCELLI SCORREVOLI

SYSTEMS FOR  
SLIDING GATES



# ELECTROMECHANICAL IRREVERSIBLE GEAR MOTOR FOR SLIDING GATES



**TURBO 30**



**TURBO 40**

## Technical Data

Specification	Turbo 30	Turbo 40
Central unit	: CT-24M	: -
Power	: 230 Vac (24 Vdc)	: 230 Vac
Rated absorbed power	: 120 W	: 300 W
Motor absorption	: 5 A	: 1,3 A
Condenser	: -	: 12,5 $\mu$ F
Protection degree	: 54 IP	: 44 IP
Couple	: 10 Nm	: 16 Nm
Speed	: 0,20 m/s	: 0,16 m/s
Thrust force	: 300 N	: 400 N
Max gate weight	: 300 Kg	: 400 Kg
Thermal protection	: -	: 150 °C
Insulation class	: 1	: 1
Temporary service	: 80 %	: 30 %
Running temperature	: -20° +70°C	: -20° +70°C
Weight	: 10,5 Kg	: 12 Kg

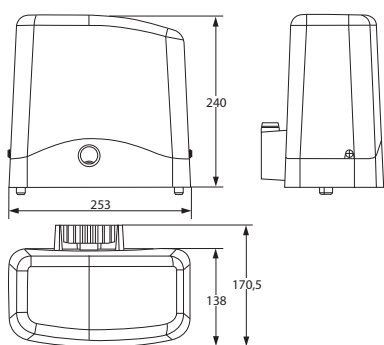

**TURBO 30**

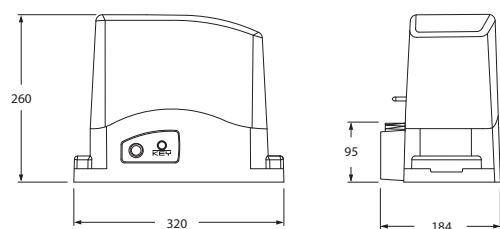

**TURBO 40**

